



American Metal Specialties, Inc.

www.cablerailings.com

(253) 272-9344 (888) 372-9344

(253) 627-3843 Fax

Customer Information

Individual Contractor

Name _____

Address _____

City _____

State _____ Zip _____

Phone _____

Fax _____

Email _____

TOP RAILS

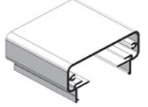

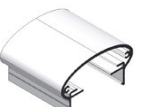

Flat
3 1/2"W x 1 7/8"H 

Elliptical
3 1/2"W x 1 7/8"H 

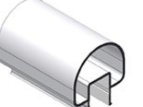
STAIR GRIP RAIL

TR for Wood Cap
2 2/3"W x 3/4"H 

Round
2"W x 2 3/16"H 

RAIL HEIGHT <input type="checkbox"/> 36" <input type="checkbox"/> 42" <input type="checkbox"/> Custom _____	POST ATTACHMENT <input type="checkbox"/> Deck Mount (Top Surface) <input type="checkbox"/> Fascia Mount (Side Mount)			
MOUNTING SURFACE <input type="checkbox"/> Wood <input type="checkbox"/> Concrete Slab <input type="checkbox"/> Composite over Wood <input type="checkbox"/> Waterproof <input type="checkbox"/> Other _____	FASCIA SIZE <input type="checkbox"/> 2" x 8" <input type="checkbox"/> 2" x 10" <input type="checkbox"/> 2" x 12" <input type="checkbox"/> Other _____			
TOP RAIL <input type="checkbox"/> Flat <input type="checkbox"/> Elliptical <input type="checkbox"/> Top Plates for Wood <input type="checkbox"/> Sub-Rail for Wood	STAIR GRIP RAIL <input type="checkbox"/> Round			
FINISH OPTIONS <input type="checkbox"/> White <input type="checkbox"/> Black <input type="checkbox"/> Brown <input type="checkbox"/> Sand <input type="checkbox"/> Clear Anodized <input type="checkbox"/> Custom _____	INFILL OPTIONS <input type="checkbox"/> 1/8" Stainless Steel Cable <input type="checkbox"/> 3/16" Stainless Steel Cable <input type="checkbox"/> 1/4" Tempered Glass <input type="checkbox"/> 5/8" Square Picket			
BOTTOM RAIL <input type="checkbox"/> Yes <input type="checkbox"/> No	GATE <input type="checkbox"/> Yes <input type="checkbox"/> No			
FINISH OPTIONS				
 BLACK	 BROWN	 SAND	 WHITE	 CLEAR ANODIZED

SKETCH AREA - Please provide a simple perimeter drawing of your project.

